

INSTRUCTIONS

INSTALLATION NOTES: READ WARNINGS PRIOR TO ATTEMPTING INSTALL

WARNING: Prior to installing the power window kit, ensure that the door and glass are in good working condition, and that the window travels smoothly both up and down the channels without falling out. This is also a good time to check/replace/install a rubber stop to keep the window from going down too far. The following instructions are to be used only as a guide as each particular installation may be different.

WARNING: Check dimensions! There must be at least one inch of clearance between the glass and door in which to mount the new regulator. In order for the window to have full travel, there must also be a minimum of seven inches below the glass (when the window is in its lowest possible position). The door must also have a minimum thickness to accommodate clearance for the window motor. The motor will occupy the bottom five inches of the regulator. When the glass is fully in the up position, the glass must extend down into the door a minimum of 1-1/2" for attachment to the regulator. If the glass is too short at this point, new glass will need to be sourced/cut at a local shop. If purchasing new glass, tempered glass will be your best option as it is both safer and stronger than conventional glass.

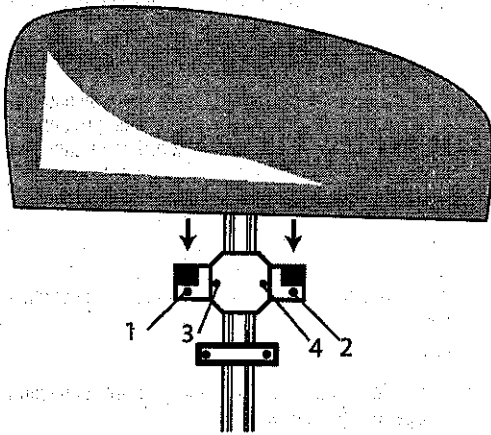

To Install Glass into the mount:

1. Loosen the two nuts on the clamps marked as "1" and "2" in the diagram. Next loosen the two bolts marked as "3" and "4" in the diagram as well as the screw marked "5".
2. Carefully slide the glass in between the clamps and snug the down nuts "1" and "2".
3. Snug down bolts "3" and "4".
4. Window glass will now be automatically balanced when opening and closing the window.

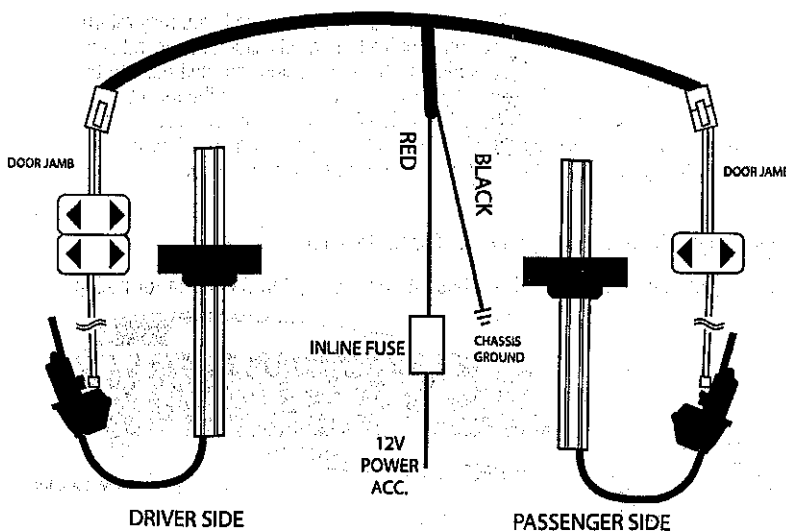

Wiring:

All the wiring is plug and play using the supplied harnesses.

Connect the red wire to a 12 volt power source, preferably the keyed ACC. Using a switched source allows the window units to work only when the key is in the "on" position.

Connect the black wire to a clean chassis grounding point.

Install the window switches as shown. Templates are included for installing the switches and switch buckets.